

WATERLINK SEPARATIONS, INC.
A Wholly Owned Subsidiary of Waterlink, Inc.
INSTALLATION, OPERATION & MAINTENANCE MANUAL

Prepared For

**RLC TECHNOLOGIES
RICHMOND, VIRGINIA**

For the Following Equipment:

**(2) MODEL SRC500
GLE SLANT RIB COALESCING OIL WATER SEPARATOR
GLE PRODUCTION #H-0013647Z**

Equipment Manufactured by:

**WATERLINK SEPARATIONS, INC.
GREAT LAKES ENVIRONMENTAL® PRODUCTS
29850 N. SKOKIE HWY (U.S. 41)
LAKE BLUFF, IL 60044-1192
(847) 473-3700
FAX: (847) 473-0477
SERVICE: (847) 235-1080
PARTS (TOLL FREE): 1-800-249-2140**

Your Great Lakes Environmental® Products Representative:

**CROCKER & ASSOCIATES, INC.
1131 MT. GALLANT ROAD
ROCK HILL, SO 29730
(803) 329-5384
FAX: (803) 366-2515**

Replacement parts can be ordered from the above offices.

**GREAT LAKES ENVIRONMENTAL® (GLE)
SLANT RIB COALESCING
OIL WATER SEPARATOR**

**INSTALLATION, OPERATION AND MAINTENANCE
MANUAL**

THIS MANUAL HAS BEEN ISSUED FOR THE
UNIT SOLD ON GLE PRODUCTION (SERIAL)
NUMBER H-0013647Z
MODEL # SRC500

PLEASE REFER TO THE H-NUMBER AND
MODEL NUMBER WHEN YOU HAVE
QUESTIONS REGARDING YOUR UNIT
OR
ORDERING SPARE PARTS



WATERLINK SEPARATIONS, INC.
A Wholly Owned Subsidiary of Waterlink, Inc.
GREAT LAKES ENVIRONMENTAL® PRODUCTS
29850 N. SKOKIE HWY (U.S. 41)
LAKE BLUFF, IL 60044-1192 • U.S.A.
(847) 473-3700 FAX: (847) 473-0477
SERVICE: (847) 235-1080
PARTS (TOLL FREE): 1-800-249-2140

TABLE OF CONTENTS

	Page No.
SECTION ONE GENERAL INFORMATION	1-1
Safety Practices	1-1 & 1-2
Inspection	1-2
Storage	1-2
Coatings	1-2
Backcharges	1-2
Additional Information	1-3
SECTION TWO TECHNICAL DESCRIPTION	2-1
Performance	2-1
Inlet Chamber	2-1
Oil Separation Chamber	2-1 & 2-2
Oil Reservoir	2-2
Sludge Chamber	2-2
Clean Water Chamber	2-2
Covers and Hatches	2-2
Tank Coating	2-3
Interior Coating	2-3
Exterior Surfaces	2-3 & 2-4
SECTION THREE INSTALLATION	3-1
Leveling	3-1 & 3-2
Anchoring	3-2
Plumbing	3-2 & 3-3
SECTION FOUR OPERATING INSTRUCTIONS	4-1
Pre-Start Up	4-1 & 4-2
Start Up	4-2 & 4-3

TABLE OF CONTENTS (cont'd.)

	Page No.
SECTION FIVE MAINTENANCE	5-1
Tankage	5-1
Sludge Removal	5-1 & 5-2
Oil Removal	5-2
Effluent Quality	5-3
Coalescer Pack	5-3 & 5-4
Dense Pack	5-4
Other Components	5-5
Lubrication Schedule	5-5
SECTION SIX REPAIR AND REPLACEMENT	6-1
Coalescer Pack	6-1
SECTION SEVEN TROUBLE-SHOOTING GUIDE	7-1
Trouble-Shooting	7-1 & 7-2
SECTION EIGHT REPLACEMENT PARTS	8-1
Replacement Parts List	8-2
SECTION NINE COMPONENT DATA	
SECTION TEN DRAWINGS	

FIGURES

<u>Title</u>	Page No.
Anchor Details	4-2A

SECTION ONE

GLE Slant Rib Coalescing Oil Water Separator GENERAL INFORMATION

Safety Practices



BEFORE INSTALLING THIS EQUIPMENT, READ AND UNDERSTAND THE PRECAUTIONS CONTAINED WITHIN THIS MANUAL.

- **DO NOT OPERATE MACHINE WITHOUT ALL GUARDS IN PLACE.**
- **ALWAYS WEAR PROTECTIVE EQUIPMENT INCLUDING PERSONAL PROTECTIVE EQUIPMENT FOR EYES, FACES, HEAD AND EXTREMITIES WHENEVER WORKING ON THE EQUIPMENT.**
- **THE CONTROL PANELS CONTAIN DANGEROUS HIGH VOLTAGES. SOME CONTROL PANELS CONTAIN VOLTAGES FROM MORE THAN ONE SOURCE. THESE CONTROL CABINETS SHOULD ONLY BE ENTERED BY A QUALIFIED ELECTRICIAN.**
- **BE SURE TO LOCK OUT POWER BEFORE MAKING ANY ADJUSTMENTS OR SERVICE TO ANY MOTORS OR DRIVES.**
- **AVOID ALL FLAMMABLE OBJECTS NEAR THE TANKS.**
- **EQUIPMENT SHOULD BE GROUNDED BEFORE START UP.**
- **DO NOT ENTER AREA OR PERFORM HOT WORK ON OR IN TANKAGE UNTIL THE ATMOSPHERE HAS BEEN TESTED AND CERTIFIED GAS FREE AND SAFE.**
- **MONITOR THE AIR PRESSURE. EXCESSIVE AIR PRESSURE CAN CAUSE AIR PUMP DAMAGE, PERSONAL INJURY OR PROPERTY DAMAGE. DO NOT EXCEED THE MAXIMUM AIR INLET PRESSURE AS STATED ON THE AIR PUMP MODEL PLATE.**

- **OBSERVE SAFE HANDLING PRACTICES THAT COMPLY WITH LOCAL AND NATIONAL LAWS AND SAFETY CODE REQUIREMENTS. OBTAIN MATERIAL SAFETY DATA SHEETS ON ALL MATERIALS THAT ARE TO BE HANDLED.**

NOTE: The information supplied in this manual is based on years of experience with the installation of our equipment and is intended only as a guide. The methods that are available to you may dictate other, more convenient procedures. The final responsibility for the installation of this equipment is not held by Waterlink Separations, Inc.

Inspection

Inspect all equipment upon arrival. If any items are missing or damaged, make note of this on the shipping papers. Also, notify Waterlink Separations, Inc. immediately at (847) 473-3700.

Storage

If the equipment is not to be installed at time of delivery, it should be stored in an area away from traffic. The ground should be level and free of sharp objects that might damage the coatings. All equipment should be stored off the ground on timbers. All factory packing should remain intact until the unit is ready for installation.

Equipment should be stored indoors. If not, care should be taken not to fill the tank(s) with water and debris. Covering all the equipment with a tarp is strongly recommended.

Coatings

All damaged coatings should be touched up immediately! Refer to the information on coating repair in Section Two of this manual.

Please contact the factory or coating manufacturer if more specific information is required.

Backcharges

Waterlink will not accept any backcharge for modifying, adjusting, servicing or any other work that has not received advanced written authorization. Authorization will only be granted when satisfactory proof is submitted and if there is a price that has been agreed upon.

Any backcharge submitted without authorization by Waterlink will be rejected in total.

Additional Information

For additional information or other installation details contact your local GLE Products Representative or contact Waterlink Separations, Inc. at 847/473-3700 or in writing at 29850 N. Skokie Highway (U.S. 41), Lake Bluff, IL, 60044-1192.

SECTION TWO

GLE Slant Rib Coalescing Oil Water Separator TECHNICAL DESCRIPTION



REVIEW ALL SAFETY PRACTICES LISTED IN SECTION ONE BEFORE PROCEEDING.

Performance

The Slant Rib Coalescing Oil/Water Separator is designed and sized to remove all non-emulsified oil from the wastewater stream and produce an effluent containing no more than 10 mg/l of oil droplets 20 micron or larger. The separation process is automatic and incorporates the use of uniquely designed slant rib, sinusoidal, oleophilic, coalescing plates arranged to induce oil droplet impingement on the plate surfaces. The slant rib plates enhance solids settling without plugging. Solids settle into a separate sludge chamber. The separator will effectively contain a 100 percent oil spill and will efficiently process variable influent flows.

Inlet Chamber

The inlet diffusion nozzle is non-clogging and disperses the flow evenly across the depth and width of the coalescing pack. Heavy solids separate in the chamber and settle into sludge collection chamber(s).

Oil Separation Chamber

The oil separation chamber contains PVC oleophilic coalescing media arranged in a configuration that provides a minimum of 42 square feet of oil coalescing surface and 10 square feet of solids settling area per cubic foot of media. Plate spacing will be $\frac{3}{4}$ inch maximum. Flow through the pack will be sinusoidal to induce oil droplet impingement on the plate surfaces. Coalesced oil will flow unimpeded along the plate surface to the top of the separation chamber where it is automatically decanted.

The media plates are installed in a vertical position and are supplied in 1 foot by 1 foot by 4 foot logs for ease of installation and removal. Each plate has a series of 90° included angle ribs. The ribs are sloped from the bottom of the separation chamber to the top at a 55° angle establishing a compound inclined surface.

Vertical slant rib plates are spaced ¾ inch apart with the slanted ribs alternating direction by 90°. This configuration induces oil droplet impingement on the oil coalescing surface for maximum oil removal efficiency. Separated oil flows to the top of the separation chamber on the underside of each rib.

Settled solids slide into the sludge chamber on the top surface of each rib.

The coalescing media is encased in a type 304 stainless steel frame with lifting lugs and can be easily installed or removed.

Oil Reservoir

The oil reservoir, located at the end of the separation chamber, has a fixed weir for automatic decant of the separated oil and is equipped with two gravity outlet nozzles located on opposite sides of the separator.

The oil reservoir can be used for temporary oil storage. An optional oil pump out package is available.

Sludge Chamber

The sludge chamber(s) for settled solids is distinct, below the coalescing pack and equipped with 45° pitched sides, baffles and outlet ports. The sludge chamber will isolate settled solids from the wastewater stream.

Clean Water Chamber

The clean water leaving the coalescing packs passes under an oil retention baffle then over an adjustable stainless steel weir and into the effluent chamber. The adjustable weir maintains liquid level in the separator. Clean water flows from the separator through a pipe outlet.

Covers and Hatches

The separator is completely covered with gasketed, removable hatches to allow access to the media pack and oil compartments. Each chamber is vented for vapor removal.

Tank Coating

Interior Coating

The interior surfaces have been sand blasted to a SSPC-SP10, near white metal blast and coated with coal tar epoxy, Tnemec 46H-413 Hi-Build Tnemec-Tar or Koppers Bitumastic 300-M, dry mil thickness of 10 mils minimum.

If properly maintained, this has been found to be a durable coating that will last throughout the life of the unit.

To properly maintain the interior surfaces, it is recommended that the tank be drained annually and given a thorough inspection. Look for cracks, pinholes and soft spots in the coating. If spots are found that need repair, remove all loose paint. Thoroughly clean the area by removing all rust. For best adhesion, the surface should be sand blasted to an SSPC-SP10, near white metal blast. Coat the area with Tnemec 46H-413 Tnemec-Tar or Koppers Bitumastic 300-M. Call Waterlink to verify which two brands of coating system was actually used for the tank. Be sure to follow all manufacturer's instructions and warnings. Where new epoxy is applied over the old one, the old coating must be clean, dry and roughened. Most importantly, the old surface MUST be prepared with a special solvent to develop a bond between the new and existing layers. After paint has cured, the equipment can be put back in service.

Exterior Surfaces

The exterior surfaces have been prepared to an SSPC-SP6, commercial blast, and given the following two-coat system:

First coat is Du-Pont Corlar 825-Y-9031/VF-Y-632 high building chromate-free primer, 4 mils minimum dry film thickness. The color is red oxide.

Finish coat is Du-Pont Imron 326 Aliphatic Polyurethane Enamel, 2 mils dry film thickness. Color is "Safety Blue" (#326-Y-23665/VG-Y-511).

Total dry film thickness to be 6 mils minimum.

This is an extremely durable coating that will stand up to the most severe weather. To properly maintain, visually inspect the tank's surfaces during normal inspection rounds. Be on the lookout for scratches that should be touched up immediately.

Note that the two-coat system uses two different colors. This allows you to notice when the finish coat is deteriorating. This should be an indication that the tank's coating should be attended to immediately.

NOTE: Maintaining the coatings is the single most important step to take in preventing deterioration of this equipment. If left unattended, an uncoated area will rust. This by itself is not only unsightly, but in due time will affect the structural integrity of this equipment.

The information on coating maintenance is supplied only as a guide. Please consult the paint manufacturer for detailed instructions on the proper maintenance and application of the coating systems used for this equipment.

SECTION THREE

GLE Slant Rib Coalescing Oil Water Separator INSTALLATION



REVIEW ALL SAFETY PRACTICES LISTED IN SECTION ONE BEFORE PROCEEDING.

Leveling

Prepare the tank site by installing the anchor bolts (if cast-in-place anchor bolts are used) or drilling the anchor holes (if expansion type, field-installed anchor bolts are used). Refer to the General Arrangement Drawing(s) supplied with this Manual for anchor bolt locations. It is also a good idea to verify the actual anchor bolt locations by measuring them on the tank.

Make sure that the site is level and is free of any sharp objects that might damage the tank coating. Shim or grout in areas where necessary.

NOTE: The levelness of the tank is very important to its functionality. It cannot be stressed enough that the leveling process be properly accomplished. It is better to invest extra time in leveling than try to correct an improperly installed tank later. A leveled tank functions better, has a better appearance and will encounter fewer problems in the future.

Remove all lids, if there are any.

The tankage should now be made as level as possible. The absolute minimum requirements being, within $\pm 3/8$ inch total from inlet end to outlet end of tank and $\pm 1/64$ inch per foot from side to side, maximum of $\pm 1/8$ inch total. Shim the tank, if necessary, until these parameters are met. Take extra precautions to make sure that any non-adjustable over weirs are made as level as physically possible. Stainless steel shim stock is recommended.

The tank will not remain level if shims are installed at random. Make sure that all shims are located under vertical tank supports.

All adjustable weirs have been set at the factory. Leveling the tank is all the adjustment that should be required. Use any fixed-weir to verify the levelness of the tank.

Anchoring

There are many methods of anchoring the equipment to the ground, any of which are acceptable for a particular installation. Please choose the method most suitable for your application.

Listed here are the most common methods for anchoring equipment:

If this equipment is to be installed in a new facility, cast-in place anchor bolts may be used. This method is acceptable for most installations but offers the least amount of flexibility. If any of the anchor bolts is off even by the slightest margin, this may require modification of the equipment to get it set properly. Most often, cast-in-place anchor bolts are used on cylindrical tanks since they allow the most adjustment if the anchor bolts are not cast in the correct location.

If this equipment is to be installed in an existing facility (or for that matter, in a new facility), expansion type anchor bolts may be the best choice. They are easy to install and offer the greatest flexibility. Just set the equipment in place and mark the locations of all anchor attachments. Drill holes of proper size and depth for the anchors chosen. Install the anchor bolts (according to manufacturer's recommendation) and set the equipment back in place.

Use pressure plates (see anchor detail drawings on page 4-2A and 4-2B) if anchor bolts are located outside of the equipment base. Either cast-in-place or expansion type anchors are acceptable.

No matter which method of anchoring is used, the bolts should be grouted in place after the equipment is up and operating. If the equipment has a channel base, access ports can be found on either side of the anchor bolt. Pour in the grout until all voids are filled. Other anchoring systems may require framing around the bolts to keep the grout in place.

Do NOT apply any grout until after the equipment is operational.

Plumbing

When making connections to the equipment, do not use the equipment as a pipe support. All plumbing should stand on its own if disconnected from equipment.

Waterlink Separations, Inc. cannot be held responsible for damage caused by using this equipment to support any piping systems before or after it.

Connections do not have to be made in the order listed below. Review the situation and make the connections in the most convenient order applicable to the installation.

Connect the outlet plumbing. For gravity flow, the effluent plumbing must be the same size or larger than the nozzle size on the equipment. Reducing the size of the effluent piping might cause hydraulic overloading of the equipment. However, when an effluent pump-out package is installed, the size of the effluent piping should be designed according to the pumping requirements. It is also recommended to run the discharge piping through as few transitions as possible, as short a distance as possible and at a pitch of not less than 1/16 inch per foot.

Connect the inlet plumbing. For gravity flow, the influent plumbing must be the same size or smaller than the nozzle size on the equipment. Increasing the size of the influent piping might cause hydraulic over-loading of the equipment. In installations where there is pump feed, the influent feed line should be adequately sized according to the feed pump requirements. Also, the pitch of the pipe should not exceed 1/16 inch per foot.

Waterlink recommends at least 10 pipe diameters of the pipe size be installed at the influent end of the tank to dissipate energy before the wastewater enters the SRC. Considerations should be taken in selecting pipe sizes and configuration at the influent end especially if the incoming water is pumped.

Connect the sludge draw-off plumbing. The tank is normally provided with two flange sludge outlets. Connect a valve (butterfly valve is recommended) at the tank sludge outlet if a valve is not yet installed.

Connect the oil outlet plumbing. The separator is designed for gravity flow into a drum or oil storage tank. The oil outlet is adequately sized to allow for 100% oil influent. If the oil outlet plumbing is reduced, consider the possibility of a 100% oil influent that may occur in the event of a large oil spill.

Four (4) threaded connections are provided for vents. The separation chamber and the effluent chamber each have at least one vent while the other services the effluent chamber. Vents are provided to prevent air locks during surge conditions. The vent exhaust should terminate at a location where noxious and/or volatile gas will not pose any hazard. For indoor installations, run the vent plumbing towards the outside of the building.

NOTE: If hazardous gases are involved in the process, consult your local authority on the handling and disposal of such gases.

SECTION FOUR

GLE Slant Rib Coalescing Oil Water Separator OPERATING INSTRUCTIONS



REVIEW ALL SAFETY PRACTICES LISTED IN SECTION ONE BEFORE PROCEEDING.

THIS EQUIPMENT MUST BE OPERATED AND MAINTAINED ONLY BY AUTHORIZED PERSONNEL WHO HAVE READ AND UNDERSTAND THE OPERATOR'S MANUAL, HAVE BEEN TRAINED IN ITS USE, AND FOLLOWING ANY AND ALL APPLICABLE SAFETY PROCEDURES.

Pre-Start Up

Inspect all piping and fittings. Check for leaks, loose connections, etc.

Inspect all coated surfaces for scratches and abrasions. Repair damaged areas immediately. Refer to Tank Coating in Section Two for the painting system applied. Contact Waterlink Separations, Inc. or the paint manufacturer for the proper application and handling of the said coating system.

In some cases the equipment may arrive with some components disassembled. This may be required to facilitate handling and shipment. If this is the case, consult the General Arrangement Drawing supplied in this manual to reassemble the component(s) to their right location(s). Refer also to that component's literature provided in this manual for installation procedures. Waterlink has made every effort in the shop to facilitate re-assembly in the field.

If a control panel is provided, on the tank, all electrical components on the tank have been pre-wired by Waterlink to the control panel. All that is needed is to bring power to the control panel. Make sure all wiring is not loose and that the control panel is grounded.

On installations where the control panel is remotely located from the tank, a junction box is provided and all electrical components have been pre-wired to terminal ends in this box. It is not Waterlink's responsibility to connect from the junction box to the control panel.

Refer to the Control Panel drawing supplied in this manual for additional information on electrical wiring.

Turn on the power to the control panel and turn on all electrical components one at a time to see if they also have power.

Start Up

Leveling and anchoring of equipment should be completed at this time. Tighten down all anchor bolts. Double nuts are recommended. Refer to the drawings on page 4-2A and 4-2B for anchoring details.

Fill the tank with clean water until it begins to flow out of the outlet pipe.

Check the oil skimming weir, making sure that it is level with the water level within 1/8 inch from side to side. If this is not the case, the tank was not leveled properly. Refer to the section on leveling to correct the problem.

The relationship between the oil skimming weir and the effluent weir is critical for the proper operation of this equipment. To check for proper adjustment:

- a. Allow the maximum rated water flow to pass through the separator.
- b. Check the oil skimming weir. Water level should be ½ inch maximum, ¼ inch minimum, below the top of the fixed oil weir at maximum flow. In the case where the water weir is adjustable and the oil weir fixed, the water weir can be lowered (or raised) to achieve the advisable gap between it and the oil weir and vice-versa.

If both water and oil weirs are adjustable, keep the water weir fixed and adjust the oil weir accordingly to achieve the recommended gap between the two.

- c. Shut off flow through the separator.
- d. Check the effluent weir, making sure that it is level with the water level within 1/16 inch. The effluent weir can be reset by loosening the bolts, moving it carefully up or down, leveling it to within 1/16 inch and tightening the bolts.
- e. Allow maximum rated flow through the separator. If the effluent weir was adjusted in step "d" above, repeat step "b". Note that the effluent weir was set for design flow and caulked at the factory before shipment.



Anchor Bolt Off Equipment.
Held In Place With
Pressure Plate.

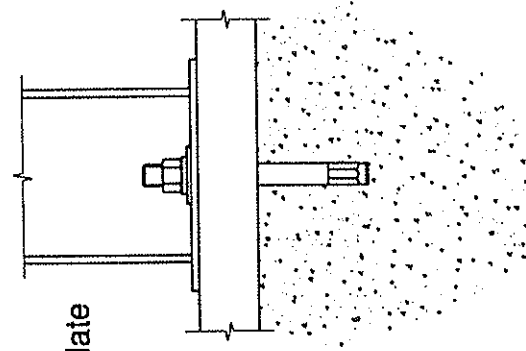
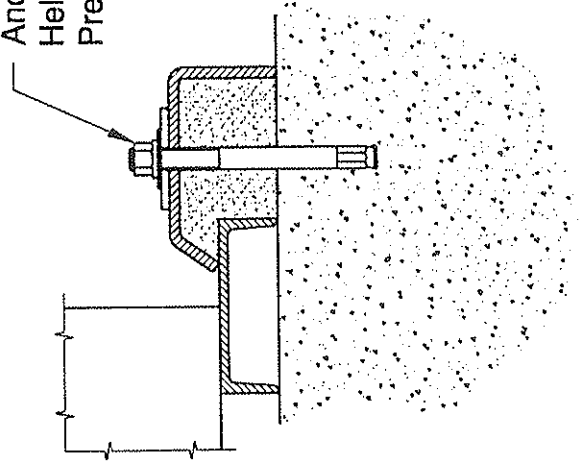

1/4" Thick Plate

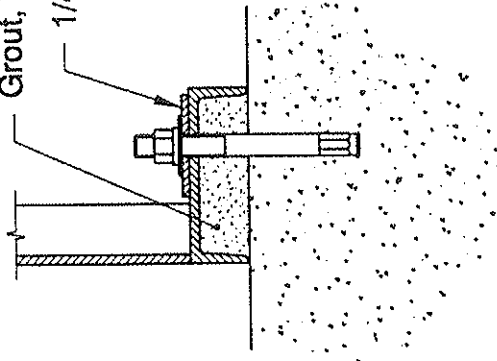

Anchor Details

Optional:

With the tank operating at maximum flow, charge the separator with oil. Slowly add oil to the separation chamber until some oil overflows into the oil reservoir. Oil used in charging should be of same type being separated by this equipment.

NOTE: Oil will float above the original water in proportion to the difference between its specific gravity and the specific gravity of the water, according to the U-Tube Principle. This means oil will automatically accumulate and spill over into the oil reservoir. If the steps above are followed, water should never spill over into the oil reservoir.

Example: Oil with a specific gravity of 0.90 has a 0.10 differential from the specific gravity of water which is 1.00. Therefore, if we let 0.10 equal $\frac{1}{4}$ inch then, 0.90 equals 2- $\frac{1}{4}$ inches. This means that an oil layer which has a total depth of 2- $\frac{1}{2}$ inches, will have $\frac{1}{4}$ inch of that layer above the original water level.

Check for leaks at all piping connections.

Pump suction lines have temporary screens these should be removed prior to putting the unit into continuous service

SECTION FIVE

GLE Slant Rib Coalescing Oil Water Separator MAINTENANCE



REVIEW ALL SAFETY PRACTICES LISTED IN SECTION ONE BEFORE PROCEEDING.

THIS EQUIPMENT MUST BE OPERATED AND MAINTAINED ONLY BY AUTHORIZED PERSONNEL WHO HAVE READ AND UNDERSTAND THE OPERATOR'S MANUAL, HAVE BEEN TRAINED IN ITS USE, AND FOLLOWING ANY AND ALL APPLICABLE SAFETY PROCEDURES.

Tankage

Periodically inspect the tank coating system if it is still intact, otherwise, correct problem areas immediately.

Inspect the integrity of all gaskets around the lids. Any signs of deterioration or undesired leakage should be attended to at once.

Ensure that all gasket materials on flanges are in good condition to prevent any leakage problems.

Do not allow vapor pressure to develop inside the tank. Make sure the tank is vented

Sludge Removal

Sludge should be drawn off regularly and not allowed to accumulate. If left unattended, the sludge level will rise to a point where it will begin to interfere with the operation of the coalescing plate pack(s).

A simple method to determine a schedule for sludge removal is outlined below:

- a. Determine the sludge capacity of the unit. Refer to the General Arrangement Drawing supplied with this manual for this information.
- b. Allocate an area/tank for storing and decanting the accumulated sludge.

- c. Arrange for the proper disposal of the sludge, either by further treatment (sludge dewatering, etc.) or by having a service dispose of the waste.
- d. The time interval between sludge draw-off is dependent on the solids loading of the wastewater. Initially, under normal loading conditions, wait for at least an hour after the tank has been filled with wastewater before starting to draw off sludge. Visual inspection should indicate the quality of sludge being drawn. This can be used as a gauge to determine the time interval between sludge draw-offs and the duration of each draw-off.

With a sludge pump out package installed, sludge is drawn off on an intermittent or continuous basis by a repeat cycle timer. This timer can be set from 0-100 hours. A selector switch provided on the panel will provide automatic operation with manual override.

- e. Keep a chart on when and how long sludge was drawn off and the amount of sludge generated per decanting period. This will allow you to better determine sludge the draw-off interval and duration that best works for the installation.

Oil Removal

Oil should be drawn off regularly and not allowed to accumulate. If left unattended, the accumulated oil volume will increase to a point where it will begin to interfere with the operation of the coalescer pack.

A simple method to determine a schedule for oil removal is outlined below:

- a. Determine the oil capacity of the unit. Refer to the General Arrangement Drawing supplied with this manual for this information.
- b. Allocate an area/tank for storing and decanting the accumulated oil.
- c. Arrange for the proper disposal of the oil, either by further treatment or by having a service dispose of the waste.
- d. Oil is designed to flow by gravity. Check to make sure the oil can freely drain from the equipment. If the outlet gets plugged, the oil will flood the separation chamber and begin to seep into the effluent chamber.

With an oil pump out package installed, a high and low level float switch mounted in the oil reservoir will automatically turn the pump on or off. The pump can be controlled from the control panel through an automatic switch with manual override.

- e. Periodically check the level switch to make sure it is activated at the desired levels.

Effluent Quality

Regularly monitor the quality of the effluent leaving the separator. If any loss in effluent quality is observed, steps should be taken to correct the problem immediately.

Coalescer Pack

Frequency of cleaning will be dependent on the characteristics of the wastewater being processed by the media. Periodic visual inspection will determine the frequency of cleaning.

Monitor the quality of the effluent water. If the quality starts to deteriorate, this is an indication that the media may need replacement or cleaning.

The media packs are provided with accessories for securing and for maximizing coalescing media pack efficiency. These include the side baffles, top baffle and the media connector plates. These parts are secured in their designed orientation and should be returned to that original setup after removal.

Clogged solids may be due to inert debris or biological growth within the tank. If it is biological, shock-dose the system with a chlorine or biocide product. A 300:1 dilution of domestic laundry bleach or 1000:1 dilution of commercial bleach (NaClO) is recommended. Both dilution will give a 100 ppm active agent. Note that both concentrations are corrosive and that commercial bleach is hazardous so extreme care must be taken in the handling of these solutions. Expose the media to the chlorine for about one hour to eradicate the growth. If no appreciable change occurs, double the dilution strength and soak the media in this solution for an hour. Following the biocide application, use a water stream to loosen and remove the debris from the media.

If flushing in place is not enough, remove the media from the tank. Use ordinary hose to create a pressure stream. The maximum pressure so as not to damage the media is 20 psi.

After biological growth has been eradicated, remove the media from service. Cleaning compounds can then be used to remove debris and hydrocarbon film that retains solids trapped in the openings. Spray the cleaning compounds directly on to the packs.

While the packs are out of service or being reinstalled, take precautions so as not to damage them.

Replacement is generally recommended when the media is physically damaged or when the media openings have been plugged by sludge to the point that it is difficult or impossible to clean them. It is also prudent to investigate the cause of media damage - whether it is mechanical or chemical and to take corrective actions.

Mechanical damage is a result of mishandling or accident. Take extra care in handling the media.

Chemical damage is a result of the introduction of harmful chemicals in the influent water or cleaning compounds that may have been used to flush the media of debris or clogged solids. Selected solvents harmful to the media include: benzene, toluene and chlorinated substituted organics.

The maximum tolerable temperatures of the waste water for the following types of media are:

- | | | | |
|----|---------------|---|--------------|
| a. | PVC | - | 130°F (60°C) |
| b. | CPVC | - | 200°F (93°C) |
| c. | Polypropylene | - | 160°F (71°C) |

The slant rib coalescing media is a standard product of GLE. This is available in PVC, CPVC, polypropylene, polyethylene, carbon steel or stainless steel. When ordering, just specify the material, the plate spacing, the size of the logs and the number of logs required and/or the size of the frame(s).

Dense Pack (if provided)

The dense pack assembly is comprised of a 6 inch polyester reticulated foam with 20 pores per inch nominal encased in either fiberglass grating or stainless steel frame. The foam has a life expectancy of about 13.5 years under normal conditions. However, exposure to high temperature (150 degrees Fahrenheit or more) will degrade the foam at a much faster rate. The foam is also vulnerable to water at a high pH (10.5 and higher).

Because the openings in the foam are so fine, any solids trapped in the orifices will deteriorate its performance. The presence of any solids in the dense pack is in itself an indication that something is not right. Check the quality of the wastewater. There should be minimal solids carry-over by the time the water reaches the dense pack.

High viscosity oils (90-150 SSU) in time will also cause clogging of the pores.

A deterioration in the quality of the effluent might be caused by the degradation of the dense pack. Check the integrity of the foam. If the foam has eroded away to a point where it is impractical to clean, replacement is the solution. If cleaning is an option, spray the foam using high pressure clean water. If this is still not sufficient, soaking the foam in any kerosene-based solution might free any viscous oil clogging the pores of the foam.

Other Components

Refer to individual tank component's literature provided in this manual for maintenance instructions.

Lubrication Schedule

None required.

SECTION SIX

GLE Slant Rib Coalescing Oil Water Separator REPAIR AND REPLACEMENT



REVIEW ALL SAFETY PRACTICES LISTED IN SECTION ONE BEFORE PROCEEDING.

Coalescer Pack

Refer to the General Arrangement Drawings included in this manual for the location and orientation of the media packs and their accessories.

To remove the coalescer pack(s) from the unit, one must remove all brackets and connectors that join the pack(s) and tank together. First, remove the bracket hold-down plates. These hold the coalescer pack(s) in place and are located on the pack(s) closest to the influent end. These attach the coalescer pack(s) to the tank. Next, if more than one coalescer pack, remove all coalescer connector plates. These are located on the top layer of coalescer packs and hold the packs together. Finally, lift the coalescer pack(s) out vertically without scratching the inner wall of the unit.

When reinstalling the coalescer pack(s), follow the orientation guidelines as noted:

- a. Coalescer pack top baffles are always in the top layer on the packs closest to the influent end. These packs must be installed so that the top baffle is as close as possible to the influent end.
- b. Coalescer packs with side baffles are always installed so that the baffle overlaps another coalescer pack. They are never to butt against the tank wall. These are installed on all layers and rows.

After lowering the packs(s) into the unit, per the above orientation guidelines, install the bracket hold-down plates to the coalescer pack end(s) closest to the influent end. Next, if applicable, install the coalescer connector plates to the top layer of coalescer packs. Note: There are two coalescer connector plates used per connection. When properly fastened, the coalescer packs will not move in relation to the tank or each other.

SECTION SEVEN

GLE Slant Rib Coalescing Oil Water Separator TROUBLE-SHOOTING GUIDE



REVIEW ALL SAFETY PRACTICES LISTED IN SECTION ONE BEFORE PROCEEDING.

Trouble-Shooting

Listed below are some situations that may arise in the operation of the tank:

The effluent quality has deteriorated:

- a. Has the separator's design flow been exceeded? If so, return the flow rate to normal.
- b. Has the wastewater been dosed with an unusually high concentration of oil, or been mixed with unexpected chemical(s)?
- c. Has sludge been allowed to accumulate to a point where it has started to affect the performance of the coalescer pack(s)? If so, the tank should be drained and the coalescer pack(s) flushed out. If the pack(s) can not be flushed out sufficiently from above, then remove the pack(s) from the unit and flush it from all sides. If the pack(s) is/are so bound up that any attempts to flush it out damage the inclined plates to render them useless, then the coalescer pack(s) will have to be replaced.
- d. Check the influent for surfactants or chemical emulsifiers. If any are present, chemical pretreatment may be necessary to counteract the effects of such agents.
- e. Check to make sure that the oil can freely drain from the equipment to prevent spill-offs in the effluent chamber.

If an oil pump-out package is installed, the oil level in the reservoir should never exceed the fixed oil weir. Verify that the level switches are activated at the desired levels.

- F. Is the influent wastewater being pumped into the separator? If so, influent oil may be emulsified. Sample the oil/water from both before and after the pump. There should be no marked difference between the two samples. If oil is emulsified by the pump, a different type should be considered. A low RPM positive displacement pump or similar pump is recommended.

Verify also if the influent piping is at least 10 pipe diameters for the SRC influent. Incoming water might still be entering the SRC with enough energy that it tends to disturb the near-laminar flow required of SRC's.

- g. A dense pack (if not yet installed) might be needed to increase the amount and rate of oil removal.

Excessive and offensive vapor is generated:

- a. Check the quality of the wastewater.
- b. Check for any signs of deterioration of the gasket materials along the lids.
- c. Check the routing of the SRC vents.

There is a problem in removing the sludge:

- a. Is the sludge line plugged?
- b. Inspect the sludge chamber. Has the sludge been allowed to accumulate to the point of hardening where it now loses its ability to flow?
- c. Check the quality of the wastewater stream. Is it unreasonable to expect little or no sludge accumulation?

There is a problem in removing the oil:

- a. Has design flow been exceeded?
- b. Is the pump running at design capacity?
- c. Has the wastewater stream been dosed with an unusually high concentration of oil?

Refer to the component's literature supplied in the manual for their individual troubleshooting guides and techniques.

SECTION EIGHT

GLE Slant Rib Coalescing Oil Water Separator REPLACEMENT PARTS



REVIEW ALL SAFETY PRACTICES LISTED IN SECTION ONE BEFORE PROCEEDING.

Replacement parts can be ordered either through your Great Lakes Environmental® Products Representative or by contacting the Great Lakes Environmental Products Parts Coordinator toll free at **1-800-249-2140**.

Please have the unit's production (serial) number **H-0013647Z** and model number **SRC500** as shown on the front cover, available. This will ensure the accuracy of the part identification.

Accurate part identification will be verified prior to processing your order.

Replacement Parts List

GLE Slant Rib Coalescing Oil Water Separator
Model SRC

NOTE: Please give the production (serial) number (H-0013647Z) and model number (SRC500) shown on the front cover when ordering replacement parts. This will ensure accurate part identification.

<u>DESCRIPTION</u>	<u>SIZE – W x H x L</u>	<u>PART NUMBER</u>	<u>QTY. PER UNIT</u>
Coalescer Pack	4' x 4' x 4'	5029-010-010 w/Top Baffle)	2
Coalescer Pack	4' x 4' x 4'	5029-010-013 w/o Top Baffle)	2

The media itself is ¾" spacing PVC.

SECTION NINE

GLE Slant Rib Coalescing Oil Water Separator
COMPONENT DATA

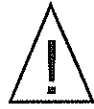

DANGER



**REVIEW ALL SAFETY PRACTICES LISTED IN SECTION ONE BEFORE
PROCEEDING.**

SECTION TEN

GLE Slant Rib Coalescing Oil Water Separator
DRAWINGS



DANGER



**REVIEW ALL SAFETY PRACTICES LISTED IN SECTION ONE BEFORE
PROCEEDING.**

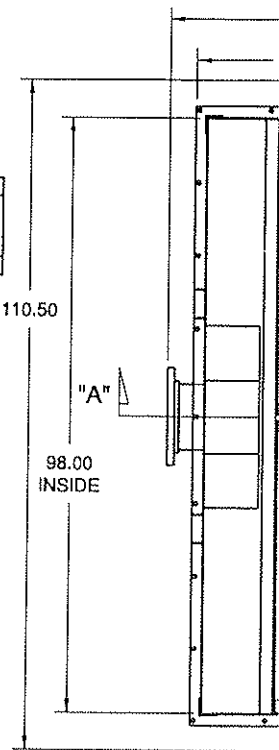
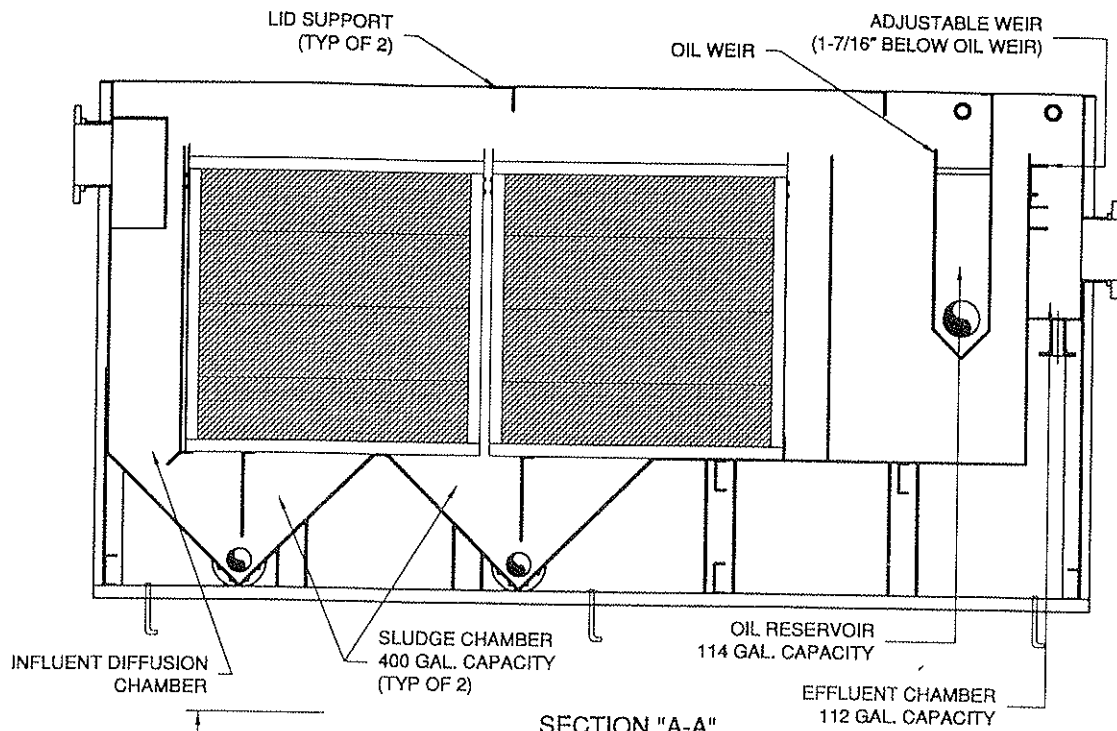

62.00=MIN. HEADROOM REQ'D. TO REMOVE COALESCER PACK

EXERTING FORCE AT AN ANGLE WHEN LIFTING TANK MAY RESULT IN THE DEFORMATION OF THE TANK'S SIDE WALLS.

RECOMMENDED METHOD OF LIFTING TANK IS TO ALWAYS EXERT FORCE VERTICALLY

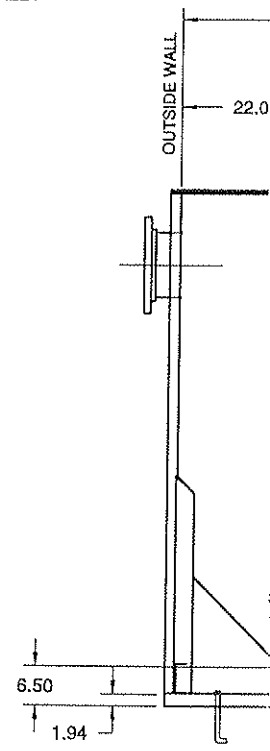
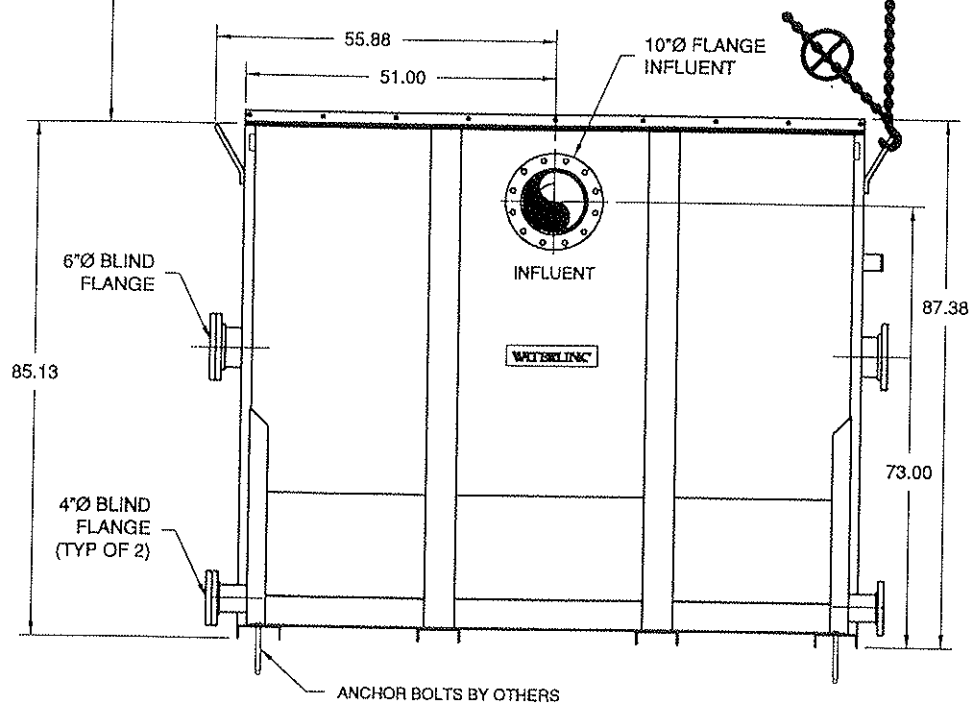

INFLUENT END ELEVATION



Property of Waterlink, Inc. All rights reserved. No part of this drawing may be reproduced in any form without permission in writing from Waterlink, Inc. Waterlink, Inc. reserves the right to alter this data or the design of its equipment at any time, without prior notice and without incurring any obligation whatsoever.

Preliminary Information Only
 For Approval Dimensions Certified

This drawing is limited to functional design, general arrangement and clearance. No responsibility is accepted by Waterlink, Inc for other dimensions, quantities, or coordination with other equipment or drawings except as stated in the purchase order.

By JPW Date 09/22/00

REV	DESCRIPTION	DATE

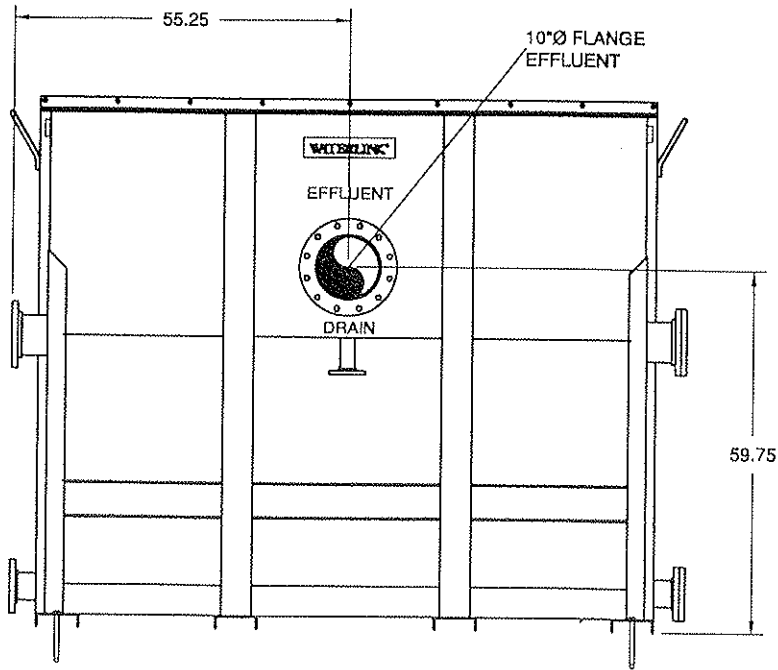

2"Ø FULL C

EFFLUENT END VIEW

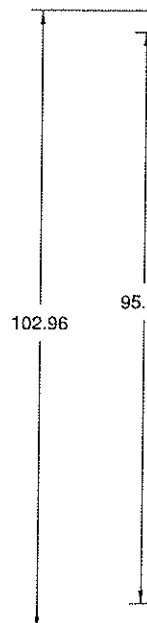

WATERLINK®

Property of Waterlink, Inc. All rights reserved. No part of this drawing may be reproduced in any form without permission in writing from Waterlink, Inc. Waterlink, Inc. reserves the right to alter this data or the design of its equipment at any time, without prior notice and without incurring any obligation whatsoever.

Preliminary Information Only
 For Approval Dimensions Certified

This drawing is limited to functional design, general arrangement and clearance. No responsibility is accepted by Waterlink, Inc for other dimensions, quantities, or coordination with other equipment or drawings except as stated in the purchase order.

By JPW Date 09/22/00

REV	DESCRIPTION	D